

TEFLON Series
(Turbine Flowmeters for Corrosive Service)

USER'S MANUAL



HP-298
January 2013

H **HOFFER FLOW CONTROLS, INC.**
Perfecting Measurement™

107 Kitty Hawk Lane • P.O. Box 2145 • Elizabeth City, North Carolina 27906-2145
1-800-628-4584 • (252) 331-1997 • FAX (252) 331-2886
www.hofferflow.com • Email: info@hofferflow.com

NOTICE

Hoffer Flow Controls, Inc. makes no warranty of any kind with regard to this material, including, but not limited to, the implied warranties of merchantability and fitness for a particular purpose.

This manual has been provided as an aid in installing, connecting, calibrating, operating, and servicing this unit. Every precaution for accuracy has been taken in the preparation of this manual; however, Hoffer Flow Controls, Inc. neither assumes responsibility for any omissions or errors that may appear nor assumes liability for any damages that result from the use of the products in accordance with information contained in the manual.

HOFFER FLOW CONTROLS' policy is to provide a user manual for each item supplied. Therefore, all applicable user manuals should be examined before attempting to install or otherwise connect a number of related subsystems.

During installation, care must be taken to select the correct interconnecting wiring drawing. The choice of an incorrect connection drawing may result in damage to the system and/or one of the components.

Please review the complete model number of each item to be connected and locate the appropriate manual(s) and/or drawing(s). Identify all model numbers exactly before making any connections. A number of options and accessories may be added to the main instrument, which are not shown on the basic user wiring. Consult the appropriate option or accessory user manual before connecting it to the system. In many cases, a system wiring drawing is available and may be requested from Hoffer Flow Controls.

This document contains proprietary information, which is protected by copyright. All rights are reserved. No part of this document may be photocopied, reproduced, or translated to another language without the prior written consent of Hoffer Flow Controls, Inc.

HOFFER FLOW CONTROLS' policy is to make running changes, not model changes, whenever an improvement is possible. This affords our customers the latest in technology and engineering. The information contained in this document is subject to change without notice.

THIS WARRANTY IS EXPRESSLY IN LIEU OF ALL OTHER WARRANTIES, EXPRESSED OR IMPLIED, INCLUDING ANY IMPLIED WARRANTY OF MERCHANTABILITY OR FITNESS FOR A PARTICULAR PURPOSE. HFC SHALL NOT BE LIABLE FOR ANY LOSS OR DAMAGE RESULTING, DIRECTLY OR INDIRECTLY, FROM THE USE OR LOSS OF USE OF THE GOODS. WITHOUT LIMITING THE GENERALITY OF THE FOREGOING, THIS EXCLUSION FROM LIABILITY EMBRACES THE PURCHASER'S EXPENSES FOR DOWNTIME OR FOR MAKING UP DOWNTIME, DAMAGES FOR WHICH THE PURCHASER MAY BE LIABLE TO OTHER PERSONS, DAMAGES TO PROPERTY, AND INJURY TO OR DEATH OF ANY PERSONS. HFC NEITHER ASSUMES NOR AUTHORIZES ANY PERSON TO ASSUME FOR IT ANY OTHER LIABILITY IN CONNECTION WITH THE SALE OR USE OF HFC'S GOODS, AND THERE ARE NO ORAL AGREEMENTS OR WARRANTIES COLLATERAL TO OR AFFECTING THE AGREEMENT. PURCHASER'S SOLE AND EXCLUSIVE REMEDY IS THE REPAIR AND/OR REPLACEMENT OF NONCONFORMING GOODS AS PROVIDED IN THE PROCEEDING PARAGRAPHS. HFC SHALL NOT BE LIABLE FOR ANY OTHER DAMAGES WHATSOEVER INCLUDING INDIRECT, INCIDENTAL, OR CONSEQUENTIAL DAMAGES.

Limited Warranty POLICY FOR Hoffer Flow Controls

HOFFER FLOW CONTROLS, INC. ("HFC") warrants HFC's Precision Series and API Series of turbine flowmeters to be free from defects in material and workmanship under normal use and service, only if such goods have been properly selected for the service intended, properly installed and properly operated and maintained as described in the turbine flowmeter manual. Reference "turbine flowmeter manual" for specific details. This warranty shall extend for a period of five (5) years from the date of shipment to the original purchaser and covers the Precision Series and API Series of flowmeters supplied with their standard hybrid ceramic ball bearings only. All other HFC products carry a one (1) year warranty. This warranty is extended only to the original purchaser ("Purchaser"). *Purchaser's sole and exclusive remedy is the repair and/or replacement of nonconforming goods as provided in the following paragraphs.*

In the event Purchaser believes the Hoffer product is defective, the product must be returned to HFC, transportation prepaid by Purchaser, within the appropriate warranty period relative to the product. If HFC's inspection determines that the workmanship or materials are defective and the required maintenance has been performed and, has been properly installed and operated, the product will be either repaired or replaced, at HFC's sole determination, free of additional charge, and the goods will be returned, transportation paid by HFC, using a transportation method selected by HFC.

Prior to returning the product to HFC, Purchaser must obtain a Returned Material Authorization (RMA) Number from HFC's Customer Service Department within 30 days after discovery of a purported breach of warranty, but not later than the warranty period; otherwise, such claims shall be deemed waived. See the Return Requests/inquiries Section of this manual.

If HFC's inspection reveals the Hoffer product to be free of defects in material and workmanship or such inspection reveals the goods were improperly used, improperly installed, and/or improperly selected for service intended, HFC will notify the purchaser in writing and will deliver the goods back to Purchaser upon receipt of Purchaser's written instructions and agreement to pay the cost of transportation. If Purchaser does not respond within thirty (30) days after notice from HFC, the goods will be disposed of in HFC's discretion.

HFC does not warrant the product to meet the requirements of any safety code of any state, municipality, or other jurisdiction, and Purchaser assumes all risk and liability whatsoever resulting from the use thereof, whether used singly or in combination with other machines or apparatus.

This warranty shall not apply to any HFC product or parts thereof, which have been repaired outside HFC's factory or altered in any way, or have been subject to misuse, negligence, or accident, or have not been operated in accordance with HFC's printed instructions or have been operated under conditions more severe than, or otherwise exceeding, those set forth in the specifications.

FOR **NON-WARRANTY** REPAIRS OR **CALIBRATIONS**, consult HOFFER FLOW CONTROLS for current repair/calibration charges. Have the following information available BEFORE contacting HOFFER FLOW CONTROLS:

1. P.O. number to cover the COST of the repair/calibration,
 2. Model and serial number of the product, and
 3. Repair instructions and/or specific problems relative to the product.
-
-

CONTENTS

1.	Introduction.....	1
1.1	Model Number Designation	2
2.	Specification	3
3.	Operation	5
3.1	Principle.....	5
3.2	Precautions	5
4.	Installation	7
5.	Maintenance.....	11
5.1	General	11
5.2	Pickup Coil Testing	11
5.3	Disassembly	12
5.4	Assembly	12
5.5	Trouble Shooting	13
5.6	Spare Parts	14

1. Introduction

We are proud that you have selected a Hoffer Turbine Flowmeter, the finest precision turbine flow transducer on the market.

The Hoffer Teflon[®] Series of turbine flow meters are designed for use in corrosive service and ultra-pure water flow applications. All wetted parts of the meters are made of Teflon.

The following information is provided for the proper installation, use, and maintenance of your instrument:

Please take a few minutes to read through this manual before installing and operating your meter. If you have any problems with the meter, refer to the maintenance and troubleshooting sections of this manual.

If you need further assistance, contact your local Hoffer Representative or contact the Hoffer Flow Controls customer service department by telephone, fax, or email for advice.

We welcome you to our growing family of satisfied customers. If you are not completely satisfied with either our product or service, we encourage you to let us know. We want to improve!

[®] Teflon is a registered trademark of E.I. DuPont de Nemours and Company, Inc.

2 Introduction

1.1 Model Number Designation

The Model number of the meter describes various fittings and options.

TEFLON LIQUID TURBINE SERIES

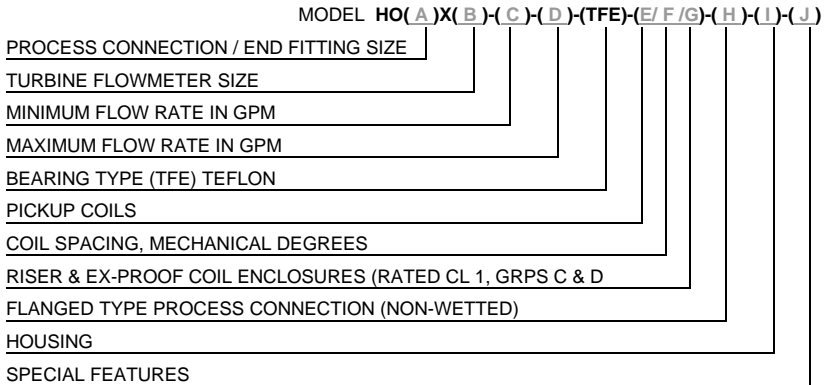

PROCESS CONNECTION/END FITTING SIZE & TURBINE FLOWMETER SIZE

MODEL HO(A)X(B)-()-()-(/ /)-()-()-()

(A)	(B)
HO 1/2	X 1/4
HO 1/2	X 3/8
HO 1/2	X 1/2
HO 3/4	X 5/8
HO 3/4	X 3/4
HO 1	X 1
HO 1 1/4	X 1 1/4
HO 1 1/2	X 1 1/2
HO 2	X 2
HO 2 1/2	X 2 1/2
HO 3	X 3

MINIMUM FLOW AND MAXIMUM FLOW RATE IN GPM

MODEL HO()X()-(C)-(D)-(/ /)-()-()-()

NOTE: NO EXTENDED RANGES ARE AVAILABLE.

(C)	(D)
<u>TURBINE SIZE</u>	<u>MINIMUM FLOW</u> TO <u>MAXIMUM FLOW</u>
1/4"	.35 GPM TO 3.5 GPM
3/8"	.75 GPM TO 7.5 GPM
1/2"	1.25 GPM TO 9.5 GPM
5/8"	1.75 GPM TO 16 GPM
3/4"	2.5 GPM TO 20 GPM
1"	4 GPM TO 45 GPM
1 1/4"	6 GPM TO 70 GPM
1 1/2"	8 GPM TO 100 GPM
2"	15 GPM TO 170 GPM
2 1/2"	37.5 GPM TO 300 GPM
3"	60 GPM TO 485 GPM

BEARING TYPE

MODEL HO()X()-()-()-(TFE)-(/ /)-()-()-()

ALL SIZES ARE TFE (PEEK)

PICKUP COILS

MODEL HO()X()-()-()-()-(/ /)-()-()-()

OPTION (E)

- (1M) ONE MAG COIL
 (2M) TWO MAG COILS
 (1ISM) ONE INTRINSICALLY SAFE MAG COIL, NORTH AMERICA
 (1ISM-ATEX) ONE ISM ATEX
 (2ISM) TWO INTRINSICALLY SAFE MAG COILS, NORTH AMERICA
 (2ISM-ATEX) TWO ISM ATEX COILS

COIL SPACING, MECHANICAL DEGREES/ASSIGNED BY TPC

MODEL HO()X()-()-()-()-(/ /)-()-()-()

NOTE (F): 90 DEGREE ELECTRICAL COIL SPACING FOR TWO COILS
 REQUIRE THE FOLLOWING MECHANICAL SPACING:

TURBINE SIZE	FORWARD MECH. DEGREES	REVERSE MECH. DEGREES	COIL SPARE DEGREES
1/4"	ZERO	135	250
3/8"	ZERO	135	250
1/2"	ZERO	135	250
5/8"	ZERO	135	180
3/4"	ZERO	135	250
1"	ZERO	135	250
1 1/4"	ZERO	135	250
1 1/2"	ZERO	135	250
2"	ZERO	101.25	250
2 1/2"	ZERO	97.50	180
3"	ZERO	97.50	180

RISER AND EXPLOSION PROOF COIL ENCLOSURES

MODEL HO()X()-()-()-()-(/ / G)-()-()-()

OPTION (G)

- (X) 1" MNPT RISER, WELDED TO BODY
 (X-ATEX) 3/4" MNPT RISER, WELDED TO BODY
 (XE2) 1" MNPT RISER WITH E2 ENCLOSURE*
 INCLUDES STOCK #300-8375 1"X3/4" ADAPTER
 (X-ATEX)E2 3/4" MNPT RISER WITH E2 ENCLOSURE*
 (X8S) 8" LONG S/S 1" MNPT RISER
 FOR FLUID TEMP. BELOW -40°F (-40°C) OR ABOVE +140°F (+60°C)
 (X8S-ATEX) 8" LONG S/S 3/4" MNPT RISER
 FOR FLUID TEMP. BELOW -40°F (-40°C) OR ABOVE +140°F (+60°C)

2B Introduction

*NOTES: EXPLOSION-PROOF/FLAME-PROOF ENCLOSURE WITH 3/4" FNPT MOUNT AND 3/4" CABLE ENTRY
 FM: CLASS I, DIV. 1, GR. ABCD, CLASS II/III, DIV. 1, GR. EFG, TYPE 4X
 CSA: CLASS I, DIV. 1, GR. ABCD, CLASS II, DIV 1, GR. EFG, CLASS III, TYPE 4X EX D IIC, CLASS I, ZONE 1, IP 66
 ATEX: EX II 2GD Ex d tD IIC, IP66/68
 IEC: EX D IIC IP68

FOR UL LISTED ENCLOSURE CONTACT FACTORY

FLANGE TYPE PROCESS CONNECTION (NON-WETTED)

MODEL HO()X()-()-()-()-(//)-(H)-()-()

ALL RING JOINT, DIN AND JIS FLANGES ADD 25% TO PRICES BELOW:

<u>PRESSURE RATING (H)</u>	<u>TURBINE SIZE</u>	<u>FLANGE CLASS/MATERIAL</u>
(F1SS)	1/2" THRU 3/4"	150# S/S
(F3SS)	"	300# S/S
(F6SS)	"	600# S/S
(F1SS)	1"	150# S/S
(F3SS)	"	300# S/S
(F6SS)	"	600# S/S
(F1SS)	1 1/4"	150# S/S
(F3SS)	"	300# S/S
(F6SS)	"	600# S/S
(F1SS)	1 1/2"	150# S/S
(F3SS)	"	300# S/S
(F6SS)	"	600# S/S
(F1SS)	2"	150# S/S
(F3SS)	"	300# S/S
(F6SS)	"	600# S/S
(F1SS)	2 1/2"	150# S/S
(F3SS)	"	300# S/S
(F6SS)	"	600# S/S
(F1SS)	3"	150# S/S
(F3SS)	"	300# S/S
(F6SS)	"	600# S/S

HOUSING

MODEL HO()X()-()-()-()-(//)-()-(L)-()

OPTION (L)

(TFE) HOUSING AND ALL WETTED PARTS ARE TFE (TEFLON)

SPECIAL FEATURES

MODEL HO()X()-()-()-()-(//)-()-()-(J)

OPTION (J)

(CE) MARK REQUIRED FOR EUROPE

(PED-CE) PED REQUIRES THAT BOTH THE OPERATING PRESSURE AND TEMPERATURE MUST BE KNOWN AND ENTERED ON THE ORDER. THIS INFORMATION WILL BE MARKED ON THE HOUSING TO MEET PED REQUIREMENTS.

(SEP-CE) SOUND ENGINEERING PRACTICE.

2. Specification

Linearity:	$\pm 1\%$ of reading over linear flow range
Repeatability:	$\pm 0.1\%$
Flow Range:	0.4 to 485 gpm
Temperature Range:	35 °F to 125 °F (1.67°C to 51.67°C)
Working Pressure:	300 psi maximum @ 70°F
Pressure Drop:	< 6 psi at maximum linear flow rate
Output:	10 mVrms or greater into 10K ohm load at minimum flow rate.

4 Specification

This page intentionally left blank.

3. Operation

3.1 Principle

All wetted components of the Hoffer Teflon® Series flowmeters are machined from virgin Teflon and have a magnet embedded in the rotor assembly. The flowing media engages the vaned rotor causing it to rotate at an angular velocity proportional to the flow rate. The pickup coil senses the spinning motion of the magnet through the housing and converts it into a pulsing electrical signal. Summation of the pulsing electrical signal relates directly to the total flow, while the frequency is linearly related to the flow rate.

3.2 Precautions

- ◆ Do not over-tighten mounting bolts and/or pickup coil. Over-tightening will result in damage to the meter.

Caution

All wetted components of the Hoffer Teflon® Series flowmeters are machined from virgin teflon. Virgin teflon, desirable because of its compatibility with a wide range of corrosive materials, lacks stability and can “cold flow” (change shape) with minimal force. Extreme care should be taken not to apply force that could cause “cold flowing” when installing or working with the meter. All threaded parts, such as the retaining nut, should be handled with extreme care. Over-tightening or applying excessive force will result in damage to the meter and will impair meter accuracy and/or meter operation.

- ◆ Do not operate the meter outside of the stated operating temperature range (35 °F to 125 °F). Operating outside the stated temperature range will result in damage to the meter.

This page intentionally left blank.

4. Installation

Upon receipt of the turbine flowmeter a visual inspection should be performed checking for any indications of damage that may have occurred during shipment. Inspect all packing material carefully for parts or auxiliary components that may have been packed with the shipment. Refer to the packing list/invoice for a detailed list of items included in the shipment.

The meter housing is marked by a flow direction arrow to indicate the calibrated direction of flow through the meter. The meter must be installed in the piping in the correct orientation to ensure the most accurate and reliable operation. Care should be taken in the proper selection of the mating fittings. Size, type of material, and pressure rating should be the same as the flowmeter supplied. The correct gaskets and bolts should be utilized.

CAUTION: *Make sure crush rings and “o” rings are installed and aligned properly with grooves on the face of meter. Refer to the assembly drawing shipped with the meter.*

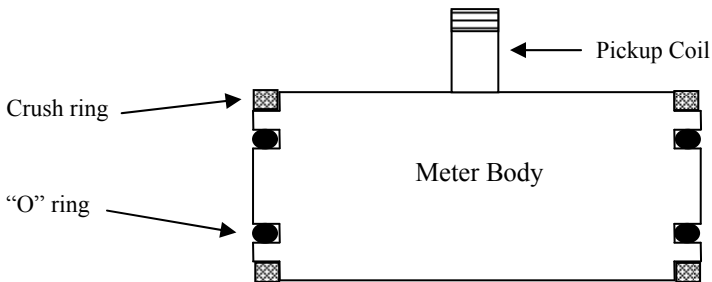

When installing the meter, tighten the mounting bolts on each end of the meter evenly until contact is made between the meter housing, gasket, and mating flanges. Tighten each bolt $\frac{1}{2}$ turn more. If leakage occurs tighten the bolts on each end equally in $\frac{1}{4}$ turn increments. Do not tighten more than one turn.

CAUTION: *Avoid over-tightening the meter mounting bolts. Over-tightening the meter mounting bolts may cause damage to the meter housing and lead to meter failure.*

When it is expected that flow will be intermittent, the meter should not be mounted at a low point in the piping system. Solids that settle or congeal in the meter may affect meter performance.

8 Installation

In order to achieve optimum electrical signal output from the flowmeter, due consideration must be given to its isolation from ambient electrical interference such as nearby motors, transformers, and solenoids.

The fluid moving through the flowmeter engages the vaned rotor and swirl present in the fluid ahead of the meter can change the effective angle of engagement and, therefore, cause a deviation from the supplied calibration (performed under controlled flow conditions). Turbine meters are constructed with flow straighteners to minimize the affects of fluid swirl and non-uniform velocity profiles and are adequate for most installations. However, it is good practice to maintain a minimum straight run of pipe approximately 10 pipe diameters ahead of the inlet and 5 pipe diameters following the outlet. Proper installation of the flowmeter minimizes the negative effects of fluid swirl.

A typical flowmeter installation is shown below:

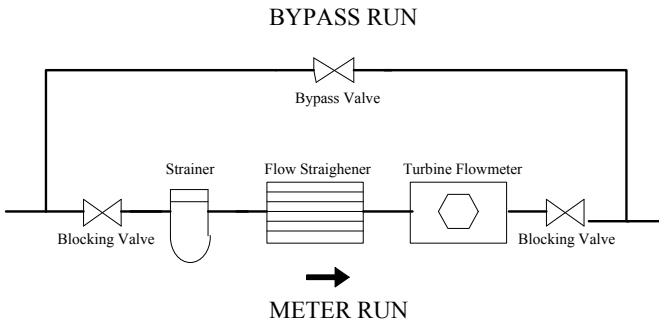

Typical Flowmeter Installation

Blocking and Bypass valves should be installed if it is necessary to do preventive maintenance on the flowmeter without shutting down the flow system. The Bypass valve can be opened before the Blocking valves allowing the flow to continue while removing the turbine flowmeter for service.

IMPORTANT: All flow lines should be purged prior to installing the meter. To prevent possible damage to the meter, install the meter **ONLY** in flow lines that are clean and free of debris.

Upon initial start-up of the system a spool piece should be installed in place of the flowmeter so that purging of the system can be performed to remove all particle debris that could cause damage to the meter internals. In applications where meter flushing is required after meter service, care should be taken as to not over-speed the meter, as severe meter damage may occur.

CAUTION: *Avoid over-spinning the meter. Over-spinning the meter may cause damage to the meter internals and lead to meter failure.*

To maintain an accurate flow measurement it is necessary to maintain a downstream pressure sufficient to prevent flashing/cavitation. Flashing of the liquid will result in an indication of flow significantly higher than the actual flow. In order to eliminate this condition adequate downstream pressure must be maintained. The minimum required downstream pressure may be calculated using the following equation:

$$\text{MinimumPressure} = (2 \times \text{PressureDrop}) + (1.25 \times \text{VaporPressure})$$

Downstream pressure may be maintained by a downstream valve that provides the necessary downstream pressure to prevent flashing/cavitation in the metering run.

This page intentionally left blank.

5. Maintenance

5.1 General

All wetted components of the Hoffer Teflon® Series flowmeters are machined from virgin Teflon. Extreme care must be used when working with these meters in order to prevent damage.

Due to the fact that the virgin Teflon, of which these meters are made, lacks stability and can “cold flow” (change shape) with a minimal amount of force, field repairs are not recommended. Should the meter require repairs, it is recommended that the meter be returned to the factory. If field repairs are made, carefully follow the disassembly and assembly instructions in the following sections:

5.2 Pickup Coil Testing

Testing the pickup coil consists of measuring the resistance with an ohmmeter.

1. Measure the resistance between pins A and pin B. The resistance should be approximately 5300 Ohms $\pm 20\%$.
2. The resistance from any pin to the case should be greater than 1 Mohm.

If either resistance measurement fails, replace the pickup coil. Firmly seat the new coil in the flowmeter and tighten the locking nut.

Pickup Connections



Standard
MAG

A - Signal (+)
B - Common (-)

Caution: *It is very important that the pickup coil NOT be over-tightened when installing. Over-tightening will result in damage to the meter housing and will impair meter accuracy and/or meter operation.*

12 Maintenance

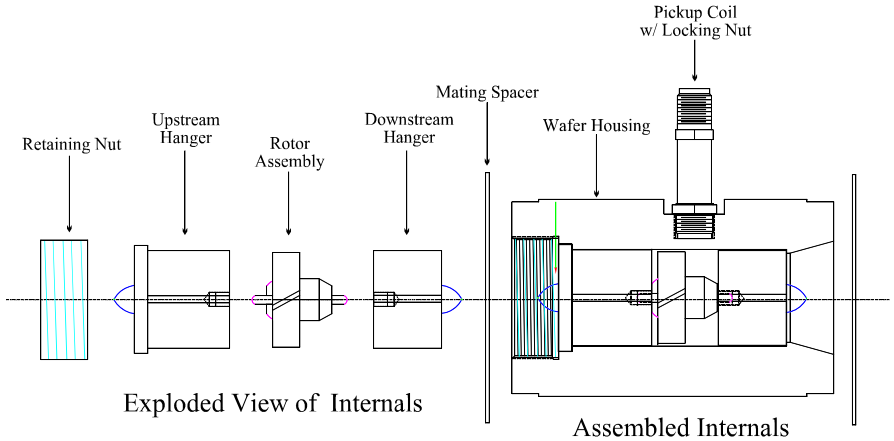

5.3 Disassembly

1. Remove the retaining nut from the inlet end of the meter by rotating the nut counter clockwise. Use a suitable spanner tool.
2. Using a blunt tool, carefully push the internals out of the meter through the outlet end.
3. Remove the coil **ONLY** if it must be replaced. If the coil is screwed directly into the Teflon housing, tools should not be used. Hand-tighten **ONLY**. **DO NOT** over-tighten!

5.4 Assembly

1. The down stream hanger is pressed into the housing with the bearing end toward the inlet end. Ensure that the hanger is firmly against the shoulder at the outlet end. Use a blunt tool so as not to damage the hanger.
2. Place the rotor assembly into the housing with the long hub end towards the downstream hanger. Ensure that the rotor shaft enters the downstream hanger bearing.
3. Place the upstream hanger in place ensuring that the rotor shaft enters the upstream hanger bearing.
4. Replace the retainer nut using an appropriate spanner tool. **DO NOT** over-tighten!
5. Check for rotor endplay. The rotor should have free lateral movement and should make a rattling noise when gently shaken from end-to-end.

5.5 Trouble Shooting

Refer to the following troubleshooting guide for assistance with possible meter malfunctions:

TROUBLE	CAUSE	REMEDY
Fluid will not flow through the meter	<ul style="list-style-type: none"> ▪ Meter clogged. ▪ Line to meter blocked. 	Clean meter. Clean line to meter.
Reduced flow through the meter	<ul style="list-style-type: none"> ▪ Meter partially clogged. ▪ Line to meter partially blocked. 	Clean meter. Clean line to meter.
Meter readings inaccurate	<ul style="list-style-type: none"> ▪ Fluid flowrate is not within meter flow range. ▪ Meter drag due to improper installation ▪ Meter drag due to temperature extremes. 	See "Specifications" for min and max flowrates. Replace meter. Shut system down & allow to cool. Replace meter, if no improvement after cooling.
Meter not giving pulse signal	<ul style="list-style-type: none"> ▪ Faulty pickup coil. ▪ Meter internals not turning due to temperature extremes. ▪ Meter internals not turning due to improper installation. 	Replace pickup coil. Shut system down & allow to cool. Replace meter, if no improvement after cooling. Replace meter.

5.6 Spare Parts

The following table contains the recommended spare parts for the Hoffer Teflon[®] Series flowmeters:

Item No.	Qty	Part No.	Part Description
1	1	300-6009	MAG Coil Pickup; PC3-24G
1	1	300-6032	Intrinsically Safe MAG Pickup; ISM-006
1	1	300-#### ¹	Retaining Nut
1	1	300-#### ¹	Upstream Hanger
1	1	300-#### ¹	Rotor Assembly
1	1	300-#### ¹	Downstream Hanger

¹ Meter internals are ordered by the size of the meter. Consult with the factory for the correct part number. Have complete meter model number available.

Dwg. No. HOX-5047 SH 1 REV --
 REVISIONS
 ZONE REV DESCRIPTION DATE APP

1
 2
 3
 4

PARTS LIST	
ITEM NO.	DESCRIPTION
1	HOUSING, TEFLON WAFER FLOWMETER
2	CRUSH RING
3	POSSUP COIL & COIL NUT
4	UPSTREAM HANGER
5	DOWNSTREAM HANGER
6	BUSHING 1/2 BEARING
7	ROTOR ASSEMBLY
8	UPSTREAM HANGER
9	RETAINING NUT
2	O-RING

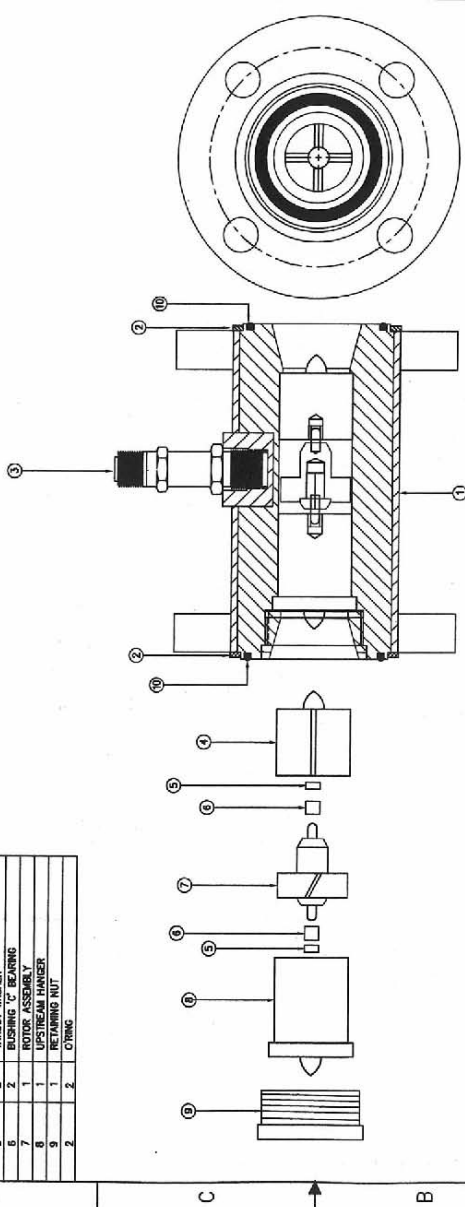

A
 B
 C
 D

MATERIAL
 FINISH

CONFIDENTIAL PROPERTY OF HOFFER FLOW CONTROLS, INC. TO BE KEPT SECRET AND NOT TO BE REPRODUCED OR USED FOR ANY OTHER PURPOSE WITHOUT THE WRITTEN PERMISSION OF HOFFER FLOW CONTROLS, INC.

USED ON
 BEST ASBY
 APPLICATION

HOFFER FLOW CONTROLS, INC.
 ELIZABETH CITY, NC 27909

ASSEMBLY DRAWING
 TEFLON WAFER FLOWMETER

DATE C 33371
 REV --
 HOX-5047

SHEET 1 OF 1