

# TURBINE FLOWMETERS BY HOFFER

Perfecting Measurement™



HO SERIES WAFER  
Turbine Flowmeters  
for Gas Service

Product Bulletin HO-SWG-100G

## TECHNICAL DATA SHEET

### OUTSTANDING FEATURES

- Cost effective design eliminates flange on meter.
- Outstanding accuracy.
- Short Wafer Series meters are rated to meet the pressure rating of any flange as listed in ASME B 16.5.
- Provides wide flow ranges 10: 1 turndown typical.



### GAS SIZE SELECTOR CHART FOR STANDARD HO SERIES TURBINE FLOWMETERS

Flowmeter Size	End Fitting Size	Repeatable Range** Based on a Gas Density of 1#/Ft <sup>3</sup>		Repeatable Range** Based on a Gas Density of .25#/Ft <sup>3</sup>	
		Magnetic Coil (ACF/M)	MCP Coil (ACF/M)	Magnetic Coil (ACF/M)	MCP Coil (ACF/M)
5/8	2	N/A	.5-10	N/A	1-10
3/4	3/4	N/A	.6 – 20	N/A	1.2 – 20
1	1	2.5 – 43	.8 – 43	5 – 43	1.6 – 43
1-1/4	1-1/4	3.5 – 100	1.25 – 100	7 – 100	2.5 – 100
1-1/2	1-1/2	5.0 – 120	1.75 – 120	10 – 120	3.5 – 120
2	2	10 – 200	3.5 – 200	20 – 200	7 – 200
2-1/2	2-1/2	15 – 500	5 – 500	30 – 500	10 – 500
3	3	20 – 600	7.5 – 600	40 – 600	15 – 600
4	4	30 – 1100	N/A	60 – 1100	N/A
5	5	40 – 1800	N/A	80 – 1800	N/A
6	6	50 – 3000	N/A	100 – 3000	N/A
8	8	100 – 4800	N/A	200 – 4800	N/A

This chart is for quick reference only and not for final size. Calculate using actual service conditions. Flow ranges shown for 15-degree blade angle only. Four standard blade angles available. \*\*Lower limit of flow range is dependent on user's operating density.

### SPECIFICATIONS

**Overrange:** 150% of maximum flow (intermittently).

**Linearity:** ±1% of reading typical.

**Repeatability:** ±.25% of reading typical.

**Available Turn Down Range:** 10:1 Typical.

**Available Temperature Range:** -450°F to +350°F . Dependent upon bearing/coil selection.

**Pressure Drop Characteristics:** 1 to 3 PSI at maximum linear flow rate.

**Materials:** 316/316L dual rated stainless steel standard. Consult with applications group for corrosive applications. Broad material list available.

Wafer Meter shown with Guide Rings to Mate to Customer's Existing Flange

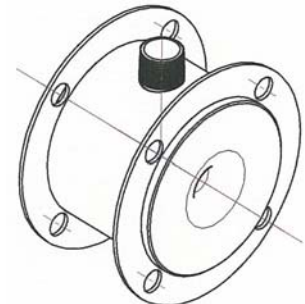

Hex Nuts per ASTM A 194 Grade 2H with flat washers and guide plates are supplied with the stud bolts.

# GAS WAFER TURBINE FLOWMETER MODEL NUMBERING SYSTEM

MODEL HO (A) X (B) - (C) - (D) - (E/F/G) - (H) - (I)

**A. End Fitting Size**

**B. Flowmeter Size**

**C. Blade Angle (See Note at bottom of page)\***

**D. Bearing Type**

(BP) Self-lubricating, ceramic hybrid ball bearings. Sizes 5/8" through 1". (-450 to +300°F)  
 (CB) Self-lubricating, ceramic hybrid ball bearings. Sizes 1-1/4" and up. (-400 to +350°F)

**E. Pickup Coils**

(1M) One Magnetic Coil  
 (2M) Two Magnetic Coils  
 (1MC3PA) One RF Coil  
 (2MC3PA) Two RF Coils  
 (1ISM) Intrinsically Safe Mag Coil  
 (2ISM) Two Intrinsically Safe Mag Coils  
 (1ISM-ATEX) One ISM ATEX magnetic coil  
 (2ISM-ATEX) TWO ISM ATEX magnetic coils  
 \_(RP\_\_\_) Redi-Pulse Coil (See Redi-Pulse Technical Data Sheet RP-XXX)  
 \_(\_\_\_ ) Intrinsically Safe Redi-Pulse Coil (See I.S. Redi-Pulse Technical Data Sheet IRP-XXX)  
 (P) Pigtail or Flying Leads, Add-P and the Length of leads after any coil except the high temperature coils  
 (-ATEX) Add after coil part number when using ATEX enclosure mounted on meter

**F. Coil Spacing, Mechanical Degrees Apart**

( ) Factory Assigned. Spacing required when meter has two pickup coils. If second coil not required skip option (F).

**G. Riser and Explosion-Proof Coil Enclosures**

(X) 1" MNPT riser, welded to body. Required for all types of enclosures.  
 (X-ATEX) 3/4" MNPT riser, welded to the body.  
 (XE2) 1" MNPT riser with E2 enclosure. (See Chart)\*\*  
 (X-ATEX)E2 3/4" MNPT riser with E2 enclosure. (See Chart)\*\*  
 (X8S) 8" Long S/S 1" MNPT riser. (For fluid temperatures below -40°F (-40°C) or above +140°F +60°C)  
 (X8S-ATEX) 8" Long S/S 3/4" MNPT riser. (For fluid temperatures below -40°F (-40°C) or above +140°F +60°C)

**\*\*E2 EXPLOSION-PROOF/FLAME-PROOF ENCLOSURE WITH 3/4" FNPT MOUNT AND 3/4" CABLE ENTRY RATINGS:**

FM:	CLASS I, DIV. 1, GR. ABCD, CLASS II/III, DIV. 1, GR. EFG, TYPE 4X
CSA:	CLASS I, DIV. 1, GR. ABCD, CLASS II, DIV. 1, GR. EFG, CLASS III, TYPE 4X EX D IIC, CLASS I, ZONE 1, IP 66
ATEX:	EX II 2GD Ex d tD IIC, IP66/68
IEC:	EX D IIC IP68

**H. End Fitting Types**

(\_\_\_) Enter Class of Customer's Existing Mating Flange. (Example: 150)

**I. Special Features**

(SW) Short Wafer  
 (CE) CE Mark - Required for Europe  
 (PED-CE) PED Mark - Required for Europe  
 (SEP-CE) Sound engineering practice  
 (SP) Any special features that are not covered in the model number, use a written description of -SP  
 (EXP) CSA Explosion-Proof Certification (See Chart)\*\*

\*Note: Blade Angle determined by density, assigned by factory or use of gas sizing program.

## HOFFER FLOW CONTROLS, INC.

107 Kitty Hawk Lane, P. O. Box 2145, Elizabeth City, NC 27906-2145  
 800-628-4584 252-331-1997 FAX 252-331-2886  
 www.hofferflow.com email: info@hofferflow.com

*The specifications contained herein are subject to change without notice and any user of said specifications should verify from the manufacturer that the specifications are currently in effect. Otherwise, the manufacturer assumes no responsibility for the use of specifications which may have been changed and are no longer in effect.*

The quality system covering the design, manufacture and testing of our products is certified to International Standard ISO 9001.

