

HP Series
Profile Insertion Flowmeters
USER'S MANUAL



HP-208
January 2013

H **HOFFER FLOW CONTROLS, INC.**
Perfecting Measurement™

107 Kitty Hawk Lane • P.O. Box 2145 • Elizabeth City, North Carolina 27906-2145
1-800-628-4584 • (252) 331-1997 • FAX (252) 331-2886
www.hofferflow.com • Email: info@hofferflow.com

NOTICE

HOFFER FLOW CONTROLS, INC. makes no warranty of any kind with regard to this material, including, but not limited to, the implied warranties of merchantability and fitness for a particular purpose.

This manual has been provided as an aid in installing, connecting, calibrating, operating, and servicing this unit. Every precaution for accuracy has been taken in the preparation of this manual; however, HOFFER FLOW CONTROLS, INC. neither assumes responsibility for any omissions or errors that may appear nor assumes liability for any damages that may result from the use of the products in accordance with information contained in the manual.

HOFFER FLOW CONTROLS' policy is to provide a user manual for each item supplied. Therefore, all applicable user manuals should be examined before attempting to install or otherwise connect a number of related subsystems.

During installation, care must be taken to select the correct interconnecting wiring drawing. The choice of an incorrect connection drawing may result in damage to the system and/or one of the components.

Please review the complete model number of each item to be connected and locate the appropriate manual(s) and/or drawing(s). Identify all model numbers exactly before making any connections. A number of options and accessories may be added to the main instrument, which are not shown on the basic user wiring. Consult the appropriate option or accessory user manual before connecting it to the system. In many cases, a system wiring drawing is available and may be requested from HOFFER FLOW CONTROLS.

This document contains proprietary information, which is protected by copyright. All rights are reserved. No part of this document may be photocopied, reproduced, or translated to another language without the prior written consent of HOFFER FLOW CONTROLS, INC.

HOFFER FLOW CONTROLS' policy is to make running changes, not model changes, whenever an improvement is possible. This affords our customers the latest in technology and engineering. The information contained in this document is subject to change without notice.

Return Requests / Inquiries

Direct all warranty and repair requests/inquiries to the Hoffer Flow Controls Customer Service Department, telephone number (252) 331-1997 or 1-800-628-4584. BEFORE RETURNING ANY PRODUCT(S) TO HOFFER FLOW CONTROLS, PURCHASER MUST OBTAIN A RETURNED MATERIAL AUTHORIZATION (RMA) NUMBER FROM HOFFER FLOW CONTROLS' CUSTOMER SERVICE DEPARTMENT (IN ORDER TO AVOID PROCESSING DELAYS). The assigned RMA number should then be marked on the outside of the return package and on any correspondence.

FOR **WARRANTY** RETURNS, please have the following information available BEFORE contacting HOFFER FLOW CONTROLS:

1. P.O. number under which the product was PURCHASED,
2. Model and serial number of the product under warranty, and
3. Repair instructions and/or specific problems relative to the product.

FOR **NON-WARRANTY** REPAIRS OR CALIBRATIONS, consult HOFFER FLOW CONTROLS for current repair/ calibration charges. Have the following information available BEFORE contacting HOFFER FLOW CONTROLS:

1. P.O. number to cover the COST of the repair/calibration,
2. Model and serial number of the product and
3. Repair instructions and/or specific problems relative to the product.

Limited Warranty

HOFFER FLOW CONTROLS, INC. ("HFC") warrants HFC's products ("goods") described in the specifications incorporated in this manual to be free from defects in material and workmanship under normal use and service, but only if such goods have been properly selected for the service intended, properly installed and properly operated and maintained. This warranty shall extend for a period of one (1) year from the date of delivery to the original purchaser (or eighteen (18) months if the delivery to the original purchaser occurred outside the continental United States). This warranty is extended only to the original purchaser ("Purchaser"). *Purchaser's sole and exclusive remedy is the repair and/or replacement of nonconforming goods as provided in the following paragraphs.*

In the event Purchaser believes the goods are defective, the goods must be returned to HFC, transportation prepaid by Purchaser, within twelve (12) months after delivery of goods (or eighteen (18) months for goods delivered outside the continental United States) for inspection by HFC. If HFC's inspection determines that the workmanship or materials are defective, the goods will be either repaired or replaced, at HFC's sole determination, free of additional charge, and the goods will be returned, transportation paid by HFC, using the lowest cost transportation available.

Prior to returning the goods to HFC, Purchaser must obtain a Returned Material Authorization (RMA) Number from HFC's Customer Service Department within 30 days after discovery of a purported breach of warranty, but no later than the warranty period; otherwise, such claims shall be deemed waived. See the Return Requests/Inquiries Section of this manual.

If HFC's inspection reveals the goods are free of defects in material and workmanship or such inspection reveals the goods were improperly used, improperly installed, and/or improperly selected for service intended, HFC will notify the purchaser in writing and will deliver the goods back to Purchaser upon (i) receipt of Purchaser's written instructions and (ii) the cost of transportation. If Purchaser does not respond within thirty (30) days after notice from HFC, the goods will be disposed of in HFC's discretion.

HFC does not warrant these goods to meet the requirements of any safety code of any state, municipality, or other jurisdiction, and Purchaser assumes all risk and liability whatsoever resulting from the use thereof, whether used singly or in combination with other machines or apparatus.

This warranty shall not apply to any HFC goods or parts thereof, which have been repaired outside HFC's factory or altered in any way, or have been subject to misuse, negligence, or accident, or have not been operated in accordance with HFC's printed instructions or have been operated under conditions more severe than, or otherwise exceeding, those set forth in the specifications for such goods.

THIS WARRANTY IS EXPRESSLY IN LIEU OF ALL OTHER WARRANTIES, EXPRESSED OR IMPLIED, INCLUDING ANY IMPLIED WARRANTY OF MERCHANTABILITY OR FITNESS FOR A PARTICULAR PURPOSE. HFC SHALL NOT BE LIABLE FOR ANY LOSS OR DAMAGE RESULTING, DIRECTLY OR INDIRECTLY, FROM THE USE OR LOSS OF USE OF THE GOODS. WITHOUT LIMITING THE GENERALITY OF THE FOREGOING, THIS EXCLUSION FROM LIABILITY EMBRACES THE PURCHASER'S EXPENSES FOR DOWNTIME OR FOR MAKING UP DOWNTIME, DAMAGES FOR WHICH THE PURCHASER MAY BE LIABLE TO OTHER PERSONS, DAMAGES TO PROPERTY, AND INJURY TO OR DEATH OF ANY PERSONS. HFC NEITHER ASSUMES NOR AUTHORIZES ANY PERSON TO ASSUME FOR IT ANY OTHER LIABILITY IN CONNECTION WITH THE SALE OR USE OF HFC'S GOODS, AND THERE ARE NO ORAL AGREEMENTS OR WARRANTIES COLLATERAL TO OR AFFECTING THE AGREEMENT. PURCHASER'S SOLE AND EXCLUSIVE REMEDY IS THE REPAIR AND/OR REPLACEMENT OF NONCONFORMING GOODS AS PROVIDED IN THE PRECEDING PARAGRAPHS. HFC SHALL NOT BE LIABLE FOR ANY OTHER DAMAGES WHATSOEVER INCLUDING INDIRECT, INCIDENTAL, OR CONSEQUENTIAL DAMAGES.

TABLE OF CONTENTS

GENERAL DESCRIPTION.....	1
APPLICATION.....	1
MODEL NUMBER DESIGNATION - LIQUID	2
MODEL NUMBER DESIGNATION - GAS	5
PRINCIPLE OF OPERATION.....	8
ELECTRICAL DESCRIPTION	8
HP SERIES SPECIFICATION.....	8
INSTALLATION	9
STRAINERS/FILTERS.....	10
MAINTENANCE.....	11
BALL BEARING REPLACEMENT	11
PICKUP COIL REPLACEMENT	12
SPARE AND REPLACEMENT PARTS	13
INSERTION DEPTH DETERMINATION.....	14
CALIBRATION CONSTANTS DETERMINATION	14

GENERAL DESCRIPTION

The Hoffer HP Series Profile/Insertion Flowmeter is designed to measure fluid (gas or liquid) flow in medium to large diameter pipes and provide an output signal that is proportional to that flow.

The flowmeter is designed to be installed, removed, and orientated without interrupting fluid flow in the pipeline. A conventional hot tap may be used to install the flowmeter.

The HP Series Flowmeter consist of a support assembly, turbine rotor, and pickup coil which provides a pulse output signal that is proportional to the fluid flow.

The support assembly portion consists of a stem, stem housing, handle, and conduit enclosure. The stem is graduated to aid in insertion to the desired depth and has a pickup coil located within its interior. The stem housing provides the necessary sealing action. The handle is used to align the sense head to the proper orientation. The conduit enclosure may be used as a junction box with connections to the turbine flowmeter or alternately as an enclosure for a preamplifier or two wire transmitter.

APPLICATION

The HP Series Profile/Insertion Flowmeter responds to the average velocity appearing across the well assembly.

To accurately measure the flow of fluid in a large diameter pipe it is necessary to locate the well assembly at an insertion depth corresponding to the average velocity. When located at a point other than that corresponding to the average velocity, a scale factor must be included (see Table B). The effective area of the pipe, as well as other factors, must be considered in order to predict the pulses per unit-volume of the flow-metering section.

Since the axis of the rotor may be moved with the handle, it is possible to obtain information on the swirl present in the pipe. The orientation that produces the maximum output frequency is the direction of flow.

The velocity may be obtained from the magnitude of the frequency output as this relates to the feet per second calibration of the well assembly. As the well assembly is inserted into the pipe, the velocity profile may be measured to determine the mean velocity point.

MODEL NUMBER DESIGNATION - LIQUID

HP INSERTION - LIQUID TURBINE SERIES

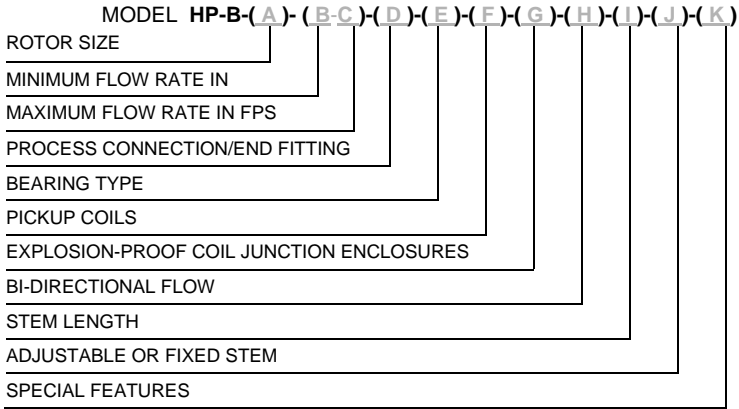

ROTOR SIZE

MODEL HP-B-(A)-()-()-()-()-()-()-()-()-()

OPTION (A)

(11/2") 11/2" ROTOR
(2") 2" ROTOR

MINIMUM FLOW AND MAXIMUM FLOW RATE IN FPS

MODEL HP-B-()-(B-C)-()-()-()-()-()-()-()-()

MINIMUM FLOW RATE IN FPS (B-)

MAXIMUM FLOW RATE IN FPS (- C)

PROCESS CONNECTION/END FITTING TYPE

MODEL HP-B-()-(-)-(D)-()-()-()-()-()-()-()

OPTION (D)

(2NPT) 2" MALE NATIONAL PIPE THREAD
(3NPT) 3" MALE NATIONAL PIPE THREAD

NOTE: ALL S/S FLANGES ARE 316L S/S DUAL RATED UNLESS OTHERWISE SPECIFIED.

BEARING TYPE

MODEL HP-B-()-(-)-(E)-()-()-()-()-()-()-()

TURBINE

SIZES OPTION (E)

11/2"	(CB)	CERAMIC HYBRID BALL BEARING, SELF LUBRICATING
	(C)	HARD CARBON COMPOSITE SLEEVE BEARING
	(T)	TUNGSTEN CARBIDE SLEEVE BEARING
2"	(CB)	CERAMIC HYBRID BALL BEARING, SELF LUBRICATING
	(C)	HARD CARBON COMPOSITE SLEEVE BEARING
	(T)	TUNGSTEN CARBIDE SLEEVE BEARING

PICKUP COILS

MODEL **HP-B-**() (-) () () (E) () () () () ()

OPTION (F)

- (1M) ONE MAG COIL
- (1MC3PA) ONE RF COIL
- (1MC2PAHT) ONE HIGH TEMP 6" PIGTAIL RF COIL
- (1HTM) HIGH TEMP MAG COIL
- (1ISM) ONE INTRINSICALLY SAFE MAG COIL, NORTH AMERICA
- (1ISM-ATEX)** ONE ISM ATEX COIL
- (1RPMXXX) ONE REDI-PULSE MAG COIL
- (1RPRXXX) ONE REDI-PULSE RF COIL
- (1DMXXXX) ONE REDI-PULSE INTRINSICALLY SAFE MAG COIL
- (1DRXXXX) ONE REDI-PULSE INTRINSICALLY SAFE RF COIL

EXPLOSION-PROOF COIL JUNCTION ENCLOSURES

MODEL **HP-B-**() (-) () () () (G) () () () ()

OPTION (G)

- (E2) E2 ENCLOSURE
- (X-ATEX)E2 3/4" MNPT RISER WITH E2 ENCLOSURE

E2 NOTES: EXPLOSION-PROOF/FLAME-PROOF ENCLOSURE WITH 3/4" FNPT MOUNT AND 3/4" CABLE ENTRY

FM: CLASS I, DIV. 1, GR. ABCD, CLASS II/III, DIV. 1, GR. EFG, TYPE 4X

CSA: CLASS I, DIV. 1, GR. ABCD, CLASS II, DIV 1, GR. EFG, CLASS III, TYPE 4X, EX D IIC, CLASS I, ZONE 1, IP 66

ATEX: EX II 2GD Ex d tD IIC, IP66/68

IEC: EX D IIC IP68

FOR UL LISTED ENCLOSURE CONTACT FACTORY

BI-DIRECTIONAL FLOW

MODEL **HP-B-**() (-) () () () () (H) () () ()

OPTION (H)

- (BF) BI-DIRECTIONAL FLOW. REQUIRES THE 2" ROTOR AND 3" END FITTING OPTIONS ABOVE.

STEM LENGTH

MODEL **HP-B-**()-(-)-()-()-()-()-()-()-()-()-()-()

OPTION (I)

INSERT INCHES REQUIRED

ADJUSTABLE OR FIXED STEM

MODEL **HP-B-**()-(-)-()-()-()-()-()-()-()-()-(J)-()

OPTION (J)

(AL) ADJUSTABLE (LOW PRESSURE 150# MAX)

(AH) ADJUSTABLE (HIGH PRESSURE, DEPENDENT UPON

(F) FIXED

SPECIAL FEATURES

MODEL **HP-B-**()-(-)-()-()-()-()-()-()-()-()-()-(K)

OPTION (K)

(CE) CE MARK REQUIRED FOR EUROPE
THE HOUSING TO MEET PED REQUIREMENTS.

(SEP-CE) SOUND ENGINEERING PRACTICE

(SP) ANY FEATURES THAT ARE NOT COVERED IN THE
MODEL NUMBER, USE A WRITTEN DESCRIPTION OF
THE -SP.

MODEL NUMBER DESIGNATION - GAS

HP INSERTION - GAS TURBINE SERIES

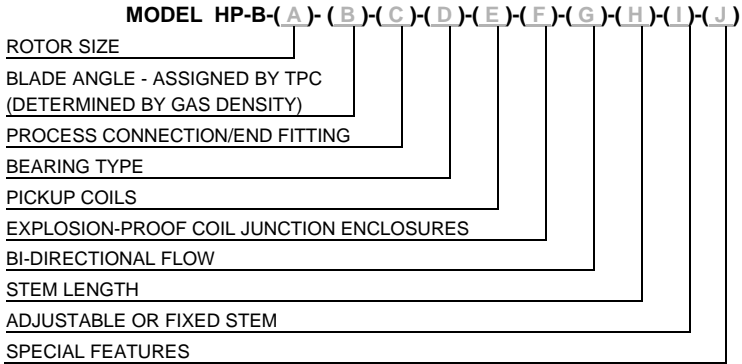

ROTOR SIZE

MODEL HP-B-(A)-()-()-()-()-()-()-()-()-()

OPTION (A)

(11/2") 11/2" ROTOR

(2") 2" ROTOR

BLADE ANGLE

MODEL HP-B-()-(B)-()-()-()-()-()-()-()-()

(B) BLADE ANGLE, ASSIGNED BY TPC

(DETERMINED BY GAS DENSITY AND FLOW RANGE)

PROCESS CONNECTION/END FITTING TYPE

MODEL HP-B-()-()-(C)-()-()-()-()-()-()-()

OPTION (C)

(2NPT) 2" MALE NATIONAL PIPE THREAD

(3NPT) 3" MALE NATIONAL PIPE THREAD

NOTE: ALL S/S FLANGES ARE 316L S/S DUAL RATED UNLESS OTHERWISE SPECIFIED.

BEARING TYPE

MODEL HP-B-()-()-()-(D)-()-()-()-()-()-()

TURBINE

SIZES OPTION (D)

11/2" (CB) CERAMIC HYBRID BALL BEARING, SELF LUBRICATING

2" (CB) CERAMIC HYBRID BALL BEARING, SELF LUBRICATING

PICKUP COILS

MODEL HP-B-()-()-()-()-(E)-()-()-()-()-()

OPTION (E)

- (1M) ONE MAG COIL
- (1MC3PA) ONE RF COIL
- (1MC2PAHT) ONE HIGH TEMP 6" PIGTAIL RF COIL
- (1HTM) HIGH TEMP MAG COIL
- (1ISM) ONE INTRINSICALLY SAFE MAG COIL, NORTH AMERICA
- (1ISM-ATEX) ONE ISM ATEX COIL
- (1RPMXXX) ONE REDI-PULSE MAG COIL
- (1RPRXXX) ONE REDI-PULSE RF COIL
- (1DMXXX) ONE REDI-PULSE INTRINSICALLY SAFE MAG COIL
- (1DRXXX) ONE REDI-PULSE INTRINSICALLY SAFE RF COIL

EXPLOSION-PROOF COIL JUNCTION ENCLOSURES

MODEL HP-B-()-(-)-()-()-(F)-()-()-()-()

OPTION (F)

- (E2) E2 ENCLOSURE
- (X-ATEX)E2 3/4" MNPT RISER WITH E2 ENCLOSURE
- E2 NOTES: EXPLOSION-PROOF/FLAME-PROOF ENCLOSURE WITH 3/4" FNPT MOUNT AND 3/4" CABLE ENTRY
- FM: CLASS I, DIV. 1, GR. ABCD, CLASS II/III, DIV. 1, GR. EFG, TYPE 4X
- CSA: CLASS I, DIV. 1, GR. ABCD, CLASS II, DIV 1, GR. EFG, CLASS III, TYPE 4X, EX D IIC, CLASS I, ZONE 1, IP 66
- ATEX: EX II 2GD Ex d tD IIC, IP66/68
- IEC: EX D IIC IP68

FOR UL LISTED ENCLOSURE CONTACT FACTORY

BI-DIRECTIONAL FLOW

MODEL HP-B-()-()-()-()-()-()-(G)-()-()-()

OPTION (G)

(BF) BI-DIRECTIONAL FLOW. REQUIRES THE 2" ROTOR AND 3" END FITTING OPTIONS ABOVE.

STEM LENGTH

MODEL HP-B-()-()-()-()-()-()-(H)-()-()

OPTION (H)

INSERT INCHES REQUIRED

ADJUSTABLE OR FIXED STEM

MODEL HP-B-()-()-()-()-()-()-()-()-(L)-()

OPTION (L)

- (AL) ADJUSTABLE (LOW PRESSURE 150# MAX)
- (AH) ADJUSTABLE (HIGH PRESSURE, DEPENDENT UPON
- (F) FIXED

SPECIAL FEATURES

MODEL HP-B-()-()-()-()-()-()-()-()-()-(J)

OPTION (J)

- (CE) CE MARK REQUIRED FOR EUROPE AND TEMPERATURE MUST BE KNOWN AND ENTERED ON THE ORDER. THIS INFORMATION WILL BE MARKED ON THE HOUSING TO MEET PED REQUIREMENTS.
- (SEP-CE) SOUND ENGINEERING PRACTICE
- (SP) ANY FEATURES THAT ARE NOT COVERED IN THE MODEL NUMBER, USE A WRITTEN DESCRIPTION OF THE -SP.

PRINCIPLE OF OPERATION

The HP Series Profile/Insertion Flowmeter is a velocity measuring, turbine type flowmeter.

The flowing fluid engages the vaned rotor causing it to rotate at an angular velocity proportional to the fluid flow rate.

The angular velocity of the rotor results in the generation of an electrical signal (AC sine wave type). Summation of the pulsing electrical signals relates directly to the total flow. The frequency of the signal relates directly to the flow rate.

The vaned rotor is the only moving part of the flowmeter.

ELECTRICAL DESCRIPTION

The pickup coil furnished with the flowmeter is a sensing device that converts the motion of the rotating rotor into essentially an AC sine wave.

Pickup Coil - The variable reluctance pickup contains a permanent magnet and associated wire-wound coil and the modulated carrier pickup contains an oscillator and associated wire-wound coil. For both coil types the movement of the of the rotor blade across the coil tip produces an AC signal within the coil winding.

Pickup Coil Output - As described above is transmitted by the shielded cable to the electronic instrumentation for proper factoring, display, and control.

HP SERIES SPECIFICATION

Materials:

Stem, Housing, Rotor Support – 304 stainless.

Bearing – 440SS shielded ball bearings, hard carbon composite, tungsten carbide sleeve.

Rotor – 17.4 stainless (Standard), Nickel 200, 430 stainless.

Seals – Rulon (Standard), Viton, Teflon.

End Fittings:

Flanged and NPT threaded are available.

Electrical:

Connections – Terminal block in conduit enclosure. Flying leads for preamp or two-wire transmitter.

Pickup – Variable reluctance type, nominal DC resistance 1300 ohms (standard). Minimum output level 10 millivolt RMS.

– Modulated Carrier type, nominal DC resistance 11.5 ohms.

Frequency Range – 0 to 500 Hz.

INSTALLATION

In choosing the location to mount the insertion meter it is recommended that there be 10 to 20 pipe diameters upstream and 5 to 10 diameters downstream. This will allow the highest measuring accuracy while tending to minimize swirl.*

Care should be exercised not to locate the HP Series Flowmeter in close proximity to electronically noisy devices which could introduce stray noise into the pickup coil. In running the signal cable from the HP Series Flowmeter to the associated electronics, care should be taken in the choice of layout so as not to introduce noise or crosstalk with other cabling. It is advisable not to run the signal cable within a conduit with power lines. Shielded cabling is required and should be terminated as specified in the manual for the electronic measurement system.

See the installation drawings for a typical installation. Make sure the riser, valve, and HP Series Flowmeter have pressure ratings suitable for the desired service conditions before installation begins. Also, check materials compatibility if the fluid is corrosive.

The HP Series Profile/Insertion Flowmeter is designed to be mounted on a full port valve which is in turn mounted on a riser welded to the pipeline.

The HP Series Flowmeter may be mounted into an active line using conventional hot tap techniques. This allows for the installation of the meter without an interruption of service.

Weld a short riser with appropriate pressure rating to the pipeline. This riser and the full port valve should have the mating fitting required by the HP Series Flowmeter. Correct gaskets and bolt types should be utilized.

At this point, a hot tap device is mounted on the valve and a hole made through the pipe wall. The hot tap device is retracted and the valve is closed.

Mount the HP Series Flowmeter to the isolating valve.

Open the full port valve to its fully open position. Insert the HP Series Flowmeter to the desired insertion depth. The stem is graduated to aid in positioning to the desired depth.

* NOTE: A swirl present in the fluid ahead of the meter can change the effective angle of engagement and, therefore, cause a deviation from the supplied calibration. Proper installation of the flowmeter minimizes the harmful effects of fluid swirl.

Aligning the handle with the center line of the pipe will also align the turbine rotor to the proper position. The turbine rotor is normally calibrated in one direction. The handle is marked with the calibrated direction of flow. A rotor may be calibrated in both directions where required. In the later application the arrow indicates the flow direction for the 'forward' calibration.

In order for the HP Series Flowmeter to properly measure fluid flow, it is necessary to insert the well assembly at the mean velocity point. At this depth, the velocity and net area of the pipe section may be used to calculate the pulses per unit-volume of the measuring section. The mean velocity point is a weak function of flow rate, as well as other factors which influence Reynolds number.

The mean velocity point may be determined using experimental methods to establish the flow profile and empirically determine the desired insertion depth (See Table C).

Table C includes the approximate location of the mean velocity point in large diameter pipes. For small diameter piping, locate the rotor in the center of the pipe to eliminate sidewall effects near the pipe wall. Due to profile effects, a scaling factor must be used with center positioning.

It should be noted that the turbine rotor responds to the average velocity appearing across its surface. While the mean velocity depth may vary, it will often remain within the diameter of the turbine rotor and thereby minimize the affects of not being exactly at the mean velocity depth.

STRAINERS/FILTERS

Profile/Insertion flowmeters are designed for use in a clean fluid service. However, the service fluid may carry some particulate material which would need to be removed before reaching the flowmeter. Under these conditions a strainer/filter may be required to reduce the potential hazard of fouling or damage that may be caused by foreign matter. Strainer/filters are recommended to be used with the Hoffer Mini-Flow Series meters.

METER SIZE	MESH SIZE	PARTICLE SIZE (Maximum)
MF Series	100	.0055
¼" to ½"	100	.0055
⅝" to 1¼"	70	.008
1½" to 3"	40	.015
4" to 12"	24	.028

If a strainer/filter is required in the system, it should be located upstream of the flowmeter taking care that the proper minimum distance is kept between the strainer and flowmeter.

MAINTENANCE

The field maintenance of the HP Series Flowmeter is limited to inspection and/or replacement of a few components.

In general, it is advisable to remove the insertion meter from the line on a periodic basis and examine it for contamination and wear.

Contamination of the rotor may occur if foreign matter succeeds in wrapping itself about the well assembly. This is easily removed. The turbine rotor should be checked for obvious damage (i.e., bent blades, shaft, etc.). If no damage is apparent and the rotor spins freely, it may be returned into service.

The types of bearings installed in the flowmeter have been selected to operate in the type of service being metered.

It is recommended that the bearings be checked periodically for wear. Since the type of fluid being measured, as well as temperature, have a direct relationship on the bearing life expectancy, it is best to contact the HFC Engineering Department for the proper preventive maintenance interval.

If the rotor wobbles on the shaft, bearing wear is indicated and necessitates replacement. If the rotor fails to spin freely, the bearings may be suspected. Ball bearings may be replaced in the field, all others should be returned to factory for rework and recalibration.

It is recommended that the bearings be replaced if any signs of wear are apparent. An unexplained shift in the output accuracy could be a sign of worn bearings.

CAUTION: *If bearings are allowed to operate without replacement at the recommended interval, the accuracy of the device may drift from the original calibration and if left long enough severe damage to the rotor may occur.*

Should the unit fail to produce an output signal while the rotor is spinning, the pickup coil may be suspect.

Complete calibrated Well Assemblies are available from Hoffer Flow Controls, Inc. Consult factory for pricing and availability.

BALL BEARING REPLACEMENT

Remove the meter to a clean, flat work surface.

To disassemble:

Loosen the stem clamp and carefully slide the housing towards the handle exposing the Well Assembly (coil and rotor housing).

Inspect the rotor and Well for damage (bent blades, bent/damaged Well supports, etc.). All damaged parts must be replaced.

Using a ¼” (for 1½” meter) or 5/16” (for 2” meter) Spintite, remove one shaft locknut.

Carefully slide the shaft out while supporting the rotor. The rotor will drop out once the shaft is removed.

Remove the deflector cones, one from each side of the Well supports.

Carefully inspect all components, replace any that may be worn or damaged.

To reassemble:

Install the deflector cones into the Well supports (one in each side).

Insert new ball bearings and shaft bushing into the rotor.

Position the rotor between the cones, making sure that the “In” side of the rotor faces into the direction of flow. Flow direction is marked on the bottom of the Well Assembly.

Install shaft.

Install shaft locknut.

Check that the rotor spins freely.

Carefully slide the housing over the Well Assembly to the “Fully Retracted” position, as marked on the stem, and tighten the clamp.

PICKUP COIL REPLACEMENT

Remove the meter to a clean, flat work surface.

To disassemble:

Disconnect the coil wires in the conduit enclosure.

Loosen the stem clamp and carefully slide the housing towards the handle exposing the Well Assembly.

Carefully unscrew and remove the Well Assembly from the stem, pulling the pickup coil wires from the stem.

Unscrew and remove the pickup coil from the Well Assembly.

To reassemble:

Install the new pickup coil into the Well Assembly.

Replace the O-ring Well Assembly seal.

Route the pickup coil wires through the center of the stem to the conduit enclosure.

Screw the Well Assembly on the stem tightening until the Well Assembly is parallel with the handle. Make sure that the flow direction of the Well Assembly is pointing in the same direction as the handle.

Carefully slide the housing over the Well Assembly to the “Fully Retracted” position, as marked on the stem, and tighten the clamp.

Reconnect the coil wires in the conduit enclosure.

SPARE AND REPLACEMENT PARTS

To assure maximum operating efficiency and minimum downtime, it is recommended that the spare parts listed in Table A be stocked.

Table A - Recommended Spare Parts

<u>Part</u>	<u>Nomenclature</u>	<u>Qty.</u>
Pickup Coil	Pickup Coil w/ leads	1
Well Assembly Seal	2-020 Viton O-Ring	1
Bearings	Ball Bearing type only	1 (set)
Well Assembly	Assembled & calibrated Well Assembly consisting of rotor, shaft, cones, well assembly frame, and O-ring seal	1

NOTE: *Recommended spare parts lists should not be construed as an indication of possible failure, but reflect material available only from the manufacturer or his authorized representative. Spare parts are recommended for a normal operating period of 18 months. Quantity of recommended spares is based upon a single unit at any given location and provisioning may be adjusted accordingly in the event that multiple units comprise a system.*

INSERTION DEPTH DETERMINATION

A review of the principles of fluid flow in pipelines reveals that the velocity of the fluid across the pipe is not constant. Under a given set of conditions a flow profile exists which varies from a parabolic shape in laminar flow to approximately flat in the turbulent flow region.

It is the average flow in the pipeline which is of interest in obtaining a measurement of flow in the pipe. For medium diameter pipes (diameters of 10 inches and less) the turbine is positioned at the center of the pipe. Center line positioning is recommended to avoid the effects of stagnant flow near the pipe wall and the turbulence of fluid near the riser. For large diameter pipes (diameters greater than 10 inches), the turbine is positioned at the depth where the flow equals the average fluid velocity of the flow.

Table C lists the required insertion depth for selected pipe diameters.

CALIBRATION CONSTANTS DETERMINATION

Calibration of the metering section consists of relating the precise velocity measurement at the specified insertion depth to the geometry of the piping to obtain a measurement of the entire flow through the metering section.

Calculate the calibration constant for the metering section (K_{MS}) using the following equation:

$$K_{MS} = \frac{K}{PF_{AVE} \times OF \times \pi \left(\frac{ID}{24}\right)^2} \quad (\text{Pulses} / \text{FT}^3)$$

$$F_{MS} = \frac{K_{MS}}{60} \quad (\text{Hz} / \text{FT}^3 / \text{Min})$$

where

- K - K FACTOR from calibration sheet (Hz/FPS)
- PF - Mean Profile Scaling Factor (equal to 1 for large diameter pipes)
- OF - Obstruction Factor
- ID - Inner diameter of pipe (inches)

A consequence of using center line positioning in medium diameter pipes is that a scaling factor, relating the average flow to the center line flow, must be included in determining the calibration constant of the metering section. In general, the profile scaling factor (PF) relates to the shape of the velocity profile under a given set of fluid conditions (i.e., Reynolds Number (Rn)). In large diameter pipes the profile scaling factor (PF) is equal to one since the turbine is located at the average velocity point.

It is necessary to consider the effects of the flow profile (PF) within the line as well as the obstruction that the stem and well assembly present to the fluid flow (OF).

The profile scaling factor may be obtained from measured data or by utilizing empirical equations derived from fluid mechanics of the fluid profile shape as a function of Reynolds Number.

Table B lists the profile scaling factor derived from one such empirical equation. To choose the correct profile scaling factor, determine the Reynolds Number corresponding to the anticipated minimum and maximum flow rates using the following equation:

for Liquid Service:

$$Rn = \frac{3160 \times Q}{ID \times \mu}$$

for Gas Service:

$$Rn = \frac{Q \times D \times 4}{\pi \times ID \times \mu}$$

where

- Q - flow in US gallons per minute
- ID - pipe bore in inches
- μ - viscosity in Centistokes

where

- Q - flow rate in SCF/sec
- D - density in #/ft³
- ID - nominal pipe ID in inches
- μ - viscosity of gas in #/in-sec

From Table B obtain the profile scaling factors corresponding to the approximate Reynolds Number.

Calculate the mean profile scaling factor using the following equation:

$$PF_{AVE} = \frac{PF_{MAX} + PF_{MIN}}{2}$$

An estimate of the error introduced into the indicated flow by the varying flow profile may be made with the aid of the following equation:

$$\% \text{ ERROR} = \frac{(PF_{MAX} - PF_{MIN})}{2 \times PF_{AVE}} \times 100\%$$

It may be noted that the percent error will increase as a larger turn down range is sought. It is therefore advisable that PF_{MAX} and PF_{MIN} be chosen to correspond to the actual conditions expected and not on the maximum and minimum capabilities of the Profile/Insertion Flowmeter.

Table B - Profile Scaling Factor Chart

Reynolds Number (Rn)	Profile Scaling Factor (PF)
4 x 10 ³	.791
6	.796
8	.797
1 x 10 ⁴	.800
2	.806
4	.811
6	.813
8	.816
1 x 10 ⁵	.818
2	.827
4	.837
6	.841
8	.847
1 x 10 ⁶	.849
2	.865
4	.865

Table C – Insertion Depth and Obstruction Factor Chart

	Nominal Pipe ID (inches)	Insertion Depth (inches)	Obstruction Factor (OF)
<i>Centerline</i>	3	1.5	.8245
	4	2.0	.8590
	5	2.5	.8827
	6	3.0	.8998
	8	4.0	.9225
	10	5.0	.9369
<i>Average Velocity Depth</i>	10	1.25	.9876
	12	1.50	.9890
	14	1.75	.9902
	16	2.00	.9912
	18	2.25	.9920
	20	2.50	.9927
	24	3.00	.9937
	30	3.75	.9949
	36	4.50	.9957
	42	5.25	.9962
	48	6.00	.9967

NOTE:

1. *Approximate insertion depth calculated by:*

$$\begin{array}{l} \text{Medium Diameter Pipe} \\ \text{(10 inches and less)} \\ \hline \text{Centerline} \\ I = 0.5 \times ID \end{array}$$

$$\begin{array}{l} \text{Large Diameter Pipe} \\ \text{(greater than 10 inches)} \\ \hline \text{Average Velocity Depth} \\ I = 0.125 \times ID \end{array}$$

2. *Obstruction factor calculated by:*

$$OF = 1 - \left(\frac{(1.0625 \times I) - 0.3535}{\pi \left(\frac{ID}{2} \right)^2} \right)$$

Where

ID - inside diameter of pipe in inches

I - insertion depth in inches